

OPERATING AND MAINTENANCE MANUAL FOR MARINE ELECTRIC WATER HEATER

HubbellTM
ELECTRIC HEATER COMPANY

BASE MODEL “MSE”



**HUBBELL
ELECTRIC HEATER COMPANY
P.O. BOX 288
STRATFORD, CT 06615**

PHONE: (203) 378-2659

FAX: (203) 378-3593

INTERNET: <http://www.hubbellheaters.com/>

-- IMPORTANT --

Always reference the full model number and serial number when calling the factory.

WARNING / CAUTION

1. Tank is to be completely filled with water and all air is to be vented before energizing.
2. Due to the rigors of transportation, all connections should be checked for tightness before heater is placed in operation.
3. Safety relief valve must be installed in tapping provided.
4. The refractory material used in heating elements may absorb some moisture during transit, periods of storage, or when subjected to a humid environment. This moisture absorption results in a cold insulation resistance of less than twenty (20) megohms. If this heater has been subjected to the above condition, each heating element must be checked for insulation resistance before energizing. A low megohm condition can be corrected by removing the terminal hardware and baking the element in an oven at 350°F -700°F for several hours or until the proper megohm reading is obtained.
5. **KEEP AWAY FROM LIVE ELECTRICAL CIRCUITS.**
Do not perform any maintenance, make any adjustments, or replace any components inside the control panel with the high voltage power supply turned on. Under certain circumstances, dangerous potentials may exist even when the power supply is off. To avoid casualties, always turn the power supply safety switch to off, turn the charge or ground the circuit before performing any maintenance or adjustment procedure.
6. The unit is designed to operate at pressure not more than 100 psi.
7. Generalized instructions and procedures cannot anticipate all situations. For this reason, only qualified installers should perform the installations. A qualified installer is a person who has licensed training and a working knowledge of the applicable codes regulation, tools, equipment, and methods necessary for safe installation of an electric resistance water heater. If questions regarding installation arise, check your local plumbing and electrical inspectors for proper procedures and codes. If you cannot obtain the required information, contact the company.

TABLE OF CONTENTS

SECTION	TITLE	PAGE #
I	GENERAL DESCRIPTION AND CONSTRUCTION	5
II	INSTALLATION	10
III	SCHEDULED MAINTENANCE AND OPERATION	14
IV	TROUBLESHOOTING	16
V	SERVICING AND REPLACEMENT OF PARTS	18
VI	MISCELLANEOUS CHARTS AND FORMULAS	26
VII	ABS TYPE APPROVAL PROGRAM	28

MODEL MSE DIMENSIONAL DATA

Storage Capacity (Gallons)	Maximum KW Input	Dimensions (Inches)			
		Diameter	Height	Floor to Inlet	Floor to T&P
6	3	14	17.5	5	12
10	10	20	21	7	15
20	10	20	33	7	27
30	20	20	41.5	7	34
40	20	20	58.75	7	51
50	58	22.75	51	7	43
65	58	26	48	8	40
80	58	26	58	8	51
100	58	26	69.5	8	62
120	58	28	69.25	8	62
40	58	26	33	7	24

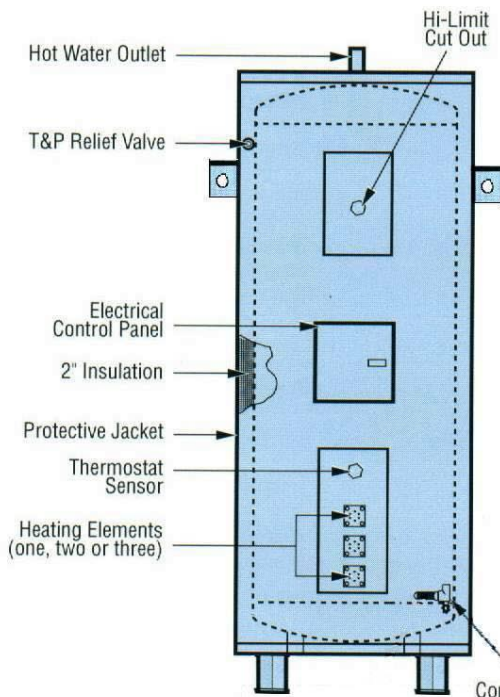
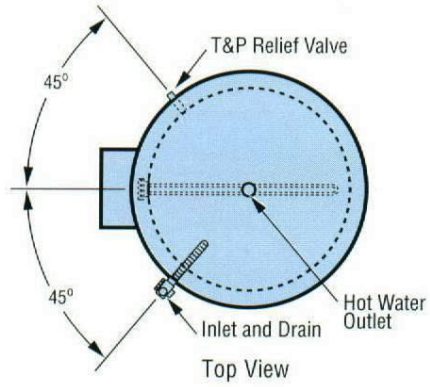

Front View

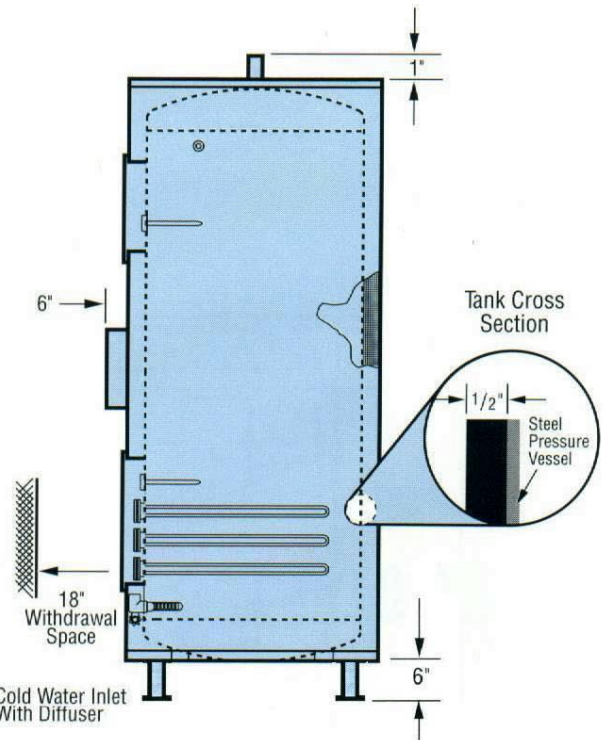

Side View

SECTION I - GENERAL DESCRIPTION AND CONSTRUCTION

GENERAL DESCRIPTION

This book describes a packaged electric water heater, approved by ABS Americas (A Division of the American Bureau of Shipping) and the USCG (United States Coast Guard), which is a stationary, self contained unit and is designed and constructed specifically for marine applications on board a surface vessel. The complete assembly consists of the storage tank, immersion electric heating element(s), thermostat, safety relief valve, safety high temperature cut out, magnetic contactor(s), and any other required electrical operating control. Optional equipment may be supplied with your unit. Please consult the product drawing for details specific to your assembly. The unit is factory assembled, insulated, jacketed, wired, tested, and ready for electrical and plumbing service connections.

CONSTRUCTION

TANK

Standard Tank Construction:

The standard storage tank is constructed of steel and internally lined with specially formulated Hydrastone cement to a ½-inch minimum thickness. The tank is designed for a maximum allowable working pressure of 100 psi (150 psi TP).

Optional Tank Construction:

Optionally, the storage tank may be constructed of all welded solid copper-silicon alloy (ASTM B-96) or type 316L stainless steel for maximum tank longevity. For these options, no internal lining is required due to the non-ferrous materials used in the construction of the pressure vessel. The tank is designed for a maximum allowable working pressure of 100 psi (150 psi TP).

TANK CONNECTIONS

The heater is supplied with separate cold water and hot water connections. Water entering the cold water inlet is deflected by means of a baffle within the tank. The hot water outlet includes a built in heat trap to prevent hot water from radiating out from the heater. A ¾-inch FNPT connection is located on the side of the heater for mounting a combination safety temperature and pressure relief valve. An overflow line should be installed from the relief valve outlet to a floor drain. A ¾-inch GHT connection is supplied for draining. See drawing for locations and sizes.

HEATING ELEMENT

The water heater is supplied with an electric immersion heating element assembly(s), composed of incoloy sheathed elements that are brazed into a brass flange. Each assembly is fastened to a corresponding tank flange using a gasket and four (4) 3/8-16 x 1-inch long hex head steel bolts and nuts. See drawing for voltage and power ratings.



CONTROL THERMOSTAT

The water heater is supplied with either a surface mounted or immersion thermostatic switch that is installed and wired at the factory. See drawing for specific details. The surface mounted thermostat can be adjusted through a range of 110° - 170° F. The immersion thermostat can be adjusted through a range of 100° - 190° F. Both thermostats are adjustable with a flat tip screwdriver.



Surface Mounted Thermostat



Immersion Thermostat

TEMPERATURE HIGH LIMIT SWITCH

As a safety device, either a surface mounted high temperature cut-off switch with manual reset, factory set at 190° F, or an immersion high temperature cut-off switch with manual reset, factory set at 180° F, is provided. In the event of an over-temperature condition, the thermostat will disengage the operating coils in the magnetic contactor(s). The high limit must be manually reset thereafter to restart the heater.

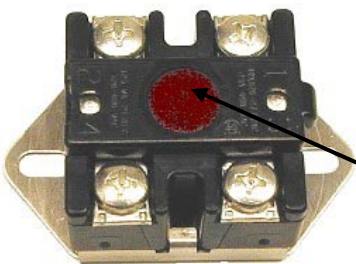

Surface Mounted High Temperature Cut-Off Switch

Manual Reset

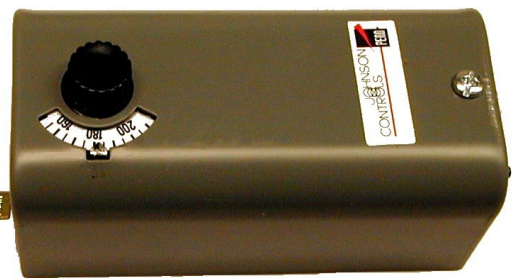

Immersion High Temperature Cut-Off Switch

MAGNETIC CONTACTOR

The magnetic contactor(s) is a heavy-duty resistive load type rated for 100,000 cycles. The contactor supplies power to the heating element(s) and is sized based on the resistive load(non-inductive) rating of the circuit. The contactor supplies power only when the thermostatic switch is engaged, thereby pulling in the contacts until the desired temperature is reached. At this point, the contacts will drop out, which in turn disconnects power from the elements.



OUTER SHELL AND INSULATION

The tank is encapsulated in 2-inch thick polyurethane foam insulation. The insulation is protected by a high impact non-corroding colored composite protective jacket.

OPTIONS

The following optional features may be included in your water heater. Reference included drawing specific to your heater for further details.

Low Water Cut-Off

Used as a safety device, the electronic low water cut-off is used to detect a low water situation and disengage the operating coils in the magnetic contactor(s). Once the condition is remedied, the low water cut-off switch is automatically reset.



Low Water Cut-Off Probe



Low Water Cut-Off Relay

Fused Low Voltage Transformer

A fused low voltage transformer may be supplied. This option is used to step down higher voltages to 120-volt for the control circuit.



Dial Temperature and Pressure Gauge

A combination temperature (70° - 250° F) and pressure (0 - 200 psi) gauge with 2½-inch dial may be supplied for in-line installation (shipped loose) or factory installed in the tank.



Vacuum Relief Valve

A vacuum relief valve may be provided with the unit to reduce the risk of back siphonage and back pressure of the system. The valve will be shipped loose for in-line installation. Instructions for installation are provided with the valve.



On/Off Switch

A built-in non-fused On/Off disconnect switch may be supplied with the control panel to disconnect power to the control panel control and power circuit wiring.

Individually Fused Elements

To prevent the possibility of damage to circuits and elements in case of electrical overloads, fuses may be supplied for each circuit. Two types of fuses may be used; a type NON for voltages less than 250-volt or type JJS for voltages less than 600-volt.



Built-in Circuit Breaker

A built-in circuit breaker may be provided with or without shunt trip protection for protection from circuit overload.

Electro-Mechanical Timer

An electro-mechanical 7-day time clock with battery back-up may be supplied for specific timing operations. A set of instructions will be supplied with the timer.



SECTION II – INSTALLATION

WARNING / CAUTION

DO NOT TURN ON THE ELECTRIC POWER SUPPLY to this equipment until heater is completely filled with water and all air has been released. *If the heater is NOT filled with water when the power is turned on, the heating elements will burn out.*

For protection against excessive pressures and temperatures, code requires the installation of a temperature-and-pressure (T&P) relief valve certified by a nationally recognized laboratory that maintains periodic inspection of production of listed equipment of materials, as meeting the requirements for Relief Valves and Automatic Gas Shutoff for Hot Water Supply Systems. ANSI Z21.22-1971. THE CUSTOMER IS RESPONSIBLE TO PROTECT PROPERTY AND PERSONNEL FROM HARM WHEN THE VALVE FUNCTIONS.

All water heaters have a risk of leakage at some unpredictable time. IT IS THE CUSTOMER'S RESPONSIBILITY TO PROVIDE A CATCH PAN OR OTHER ADEQUATE MEANS, SO THAT THE RESULTANT FLOW OF WATER WILL NOT DAMAGE PROPERTY.

WATER HEATER PLACEMENT

1. Place the heater on a solid foundation in a clean, dry location nearest to the point of most frequent hot water use.
2. The water heater should be protected from freezing and waterlines insulated to reduce energy and water waste.
3. Leave a minimum of 18" clearance for element withdrawal, if necessary.
4. Do not install in an area where flammable liquids or combustible vapors are present.

SECURING OF HEATER

1. The heater is supported by four 2-inch x 2-inch x ¼-inch thick angle iron legs each with a 3-inch x 3-inch x ¼-inch thick steel base pad. Each leg is provided with one 9/16-inch diameter bolt hole for one ½-inch bolt which should be used to secure heater to the deck.
2. In addition to the leg supports, two 3-inch x 3-inch x ¼-inch thick brackets with 7/8-inch diameter mounting holes are attached to the upper portion of the heater. These brackets should be attached to bulkhead secured tie-rods thus insuring further support of the heater for shipboard installation.

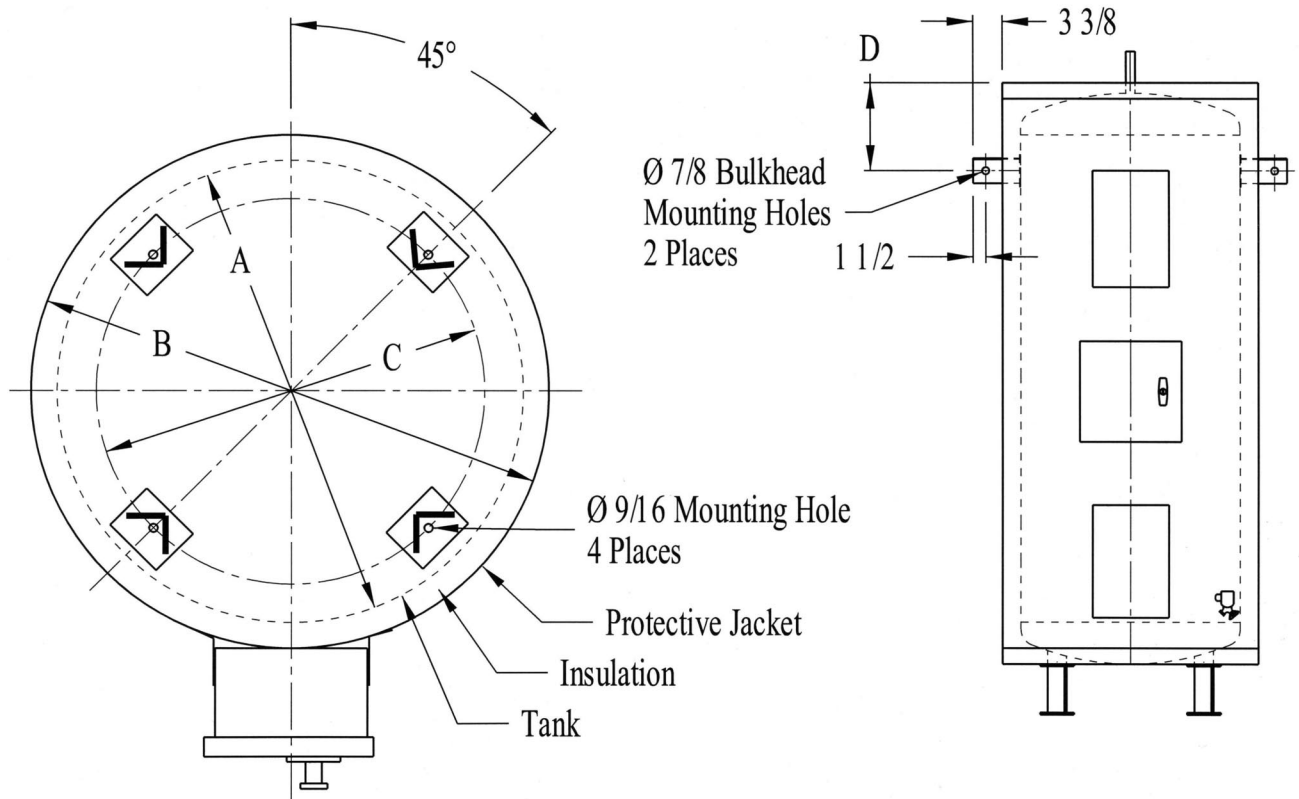

Mounting Dimensions

Tank Diameter "A"	Overall Diameter "B"	Bolt Circle "C"	Bulkhead Mounting Dimension "D"	Gallon Capacity
16	20	12	None	10
16	20	12	None	20
16	20	12	None	30
16	20	12	12	40
18 3/4	22 3/4	16	12	50
22	26	16	12	65
22	26	16	12	80
24	28	18	12	100
24	28	18	12	120

PIPING INSTALLATION

NOTE: The most effective means for preventing deterioration from accelerated corrosion due to galvanic and stray current is the installation of dielectric fittings/unions. The installation of these fittings is the responsibility of the installing contractor.

1. Connect the cold water inlet and hot water outlet to the appropriate connections as shown; refer to the drawing for location and sizes.
2. Install in-line vacuum breaker, if supplied.
3. Install in-line pressure and temperature gauge, if supplied.
4. Install the combination temperature and pressure safety relief valve in the tapping provided. Note that this is required by law for safety considerations.

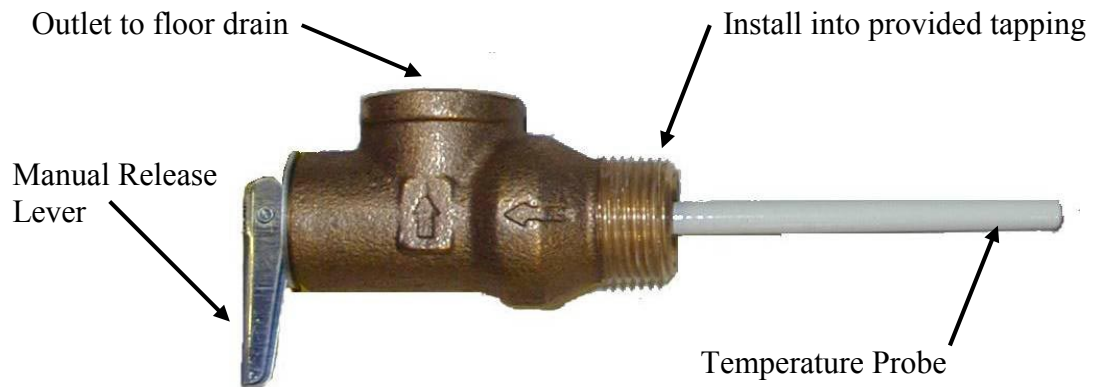

Temperature and Pressure Relief Valve

5. Install a relief valve overflow pipe to a nearby floor drain. CAUTION: No valve of any type should be installed between the relief valve and tank or in the drain line.

FILLING THE HEATER

1. Completely close the drain valve.
2. Open the highest hot water faucet to allow all air to escape from piping.
3. Open the valve to the cold water inlet and allow the heater and piping system to completely fill, as indicated by a steady flow of water from the open faucet.

ELECTRICAL INSTALLATION

1. Enter electric enclosure with properly sized feeder leads. Be sure to properly ground the water heater.
2. Install these power leads into the box lugs on the terminal block or magnetic contactor.
3. Torque screws per torque chart included in Section VI.
4. All other electrical connections are made at the factory; therefore, no other electrical connections are necessary.

FINAL CHECKS

1. Check all connections for tightness.
2. Ensure that all the above steps are completed
3. After the water is heated for the first time, monitor the water temperature as described in Section III, Quarterly Inspection.

SECTION III - SCHEDULED MAINTENANCE AND OPERATION

WARNING / CAUTION

Before performing any maintenance procedure, make certain power supply is OFF and cannot accidentally be turned on.

MAINTENANCE AND OPERATION

The water heater is automatic in its operation. It will maintain a full tank of water at the temperature setting of the thermostat. The water heater should not be turned on without first making sure that the tank is full of water and that all air has been released.

FREEZING

The tank should be fully drained in the event the electricity has been turned off and if there is danger of freezing.

QUARTERLY INSPECTION

1. Monitor thermostat
 - a. Let water heater completely heat to a designated thermostat setting.
 - b. After thermostat satisfies (that is, when the thermostat actually clicks off), draw water from heater.
 - c. Compare water temperature of drawn water to the temperature setting of the thermostat when it satisfies. Normal variation between the two points is approximately $\pm 5^{\circ}\text{F}$.
 - d. If these two readings do not coincide within acceptable tolerances and verification has been made of the accuracy of the temperature-reading gauge, replace the thermostat.
2. Lift test lever on relief valve and let water run through valve for a period of approximately 10 seconds. This will help flush away any sediment that might build up in water passageways.
3. Inspect element flange for leakage as follows:
 - a. Shut off Power Supply.
 - b. Remove element housing cover.
 - c. Visually inspect heating element gasket for evidence of leaks.
 - d. Rub finger around gasket that is between the heating element and tank flange for any evidence of moisture. If moisture is present or a water drip is observed, follow procedure outlined in Section V.
4. Check for loose electrical connections. Tighten as necessary.

ANNUAL INSPECTION

1. Flush tank as follows
 - a. Shut off power supply.
 - b. Close valve on hot water outlet piping.
 - c. Open valve on drain piping.
 - d. Cold water inlet line pressure will be strong enough to flush sediment from the bottom of the tank out through the drain. Let water run for 3-4 minutes.
 - e. Close drain valve.
 - f. Open hot water valve.
 - g. Turn power supply ON.

SECTION IV – TROUBLESHOOTING

Symptom	Probable Cause	Corrective Action / Remedy
No hot water	Circuit breaker tripped at source.	Reset circuit breaker.
	On/Off switch in 'OFF' position, if installed.	Turn switch to 'ON' position.
	Circuit breaker at control cabinet tripped, if installed.	Reset circuit breaker.
	Blown fuse in element fuse block, if installed.	Replace fuse.
	Blown fuse in transformer, if installed.	Replace fuse.
	High limit switch tripped.	Reset high limit switch.
	Loose wires.	Tighten wires. Torque screws per torque chart included in Section VI.
	Heating element inoperable.	Check heating element operation by clamping an Amprobe around each wire to the element. The ampere reading should agree with the nameplate 'AMP' figure.
	Low line voltage.	Have source electrical system checked by an electrician.
	Faulty thermostat.	Move thermostat dial through full range. A definite 'click' should be heard. If not, replace thermostat.
	Faulty low water cut-off, if installed.	Check to see if tank is full of water. If not, fill tank. If problem continues and tank is full, check for continuity between the common and normally open contact of the relay board. If continuity is not observed, replace low water cut-off.
Magnetic contactor does not energize.	Replace complete magnetic contactor. Because of the design of this particular contactor, it is more desirable to replace complete control rather than rebuilding coil, contacts and springs, etc.	

Water temperature below settings at all times	Faulty thermostat.	Check thermostat adjustment. Monitor thermostat as described in Section III, Quarterly Inspection. Replace if necessary.
	Blown fuse in element fuse block, if installed.	Replace fuse.
	Heating element not working on all phases	Check to see that heating element is working on all phases, by checking the resistance (ohms) value for each element and comparing with the chart included in Section VI.
	Heater improperly sized	Verify heater is properly sized for the flow rate and temperature rise of your system. See formulas included in Section VI. Replace elements with proper size as necessary.
Relief valve discharges continuously	Excessive temperature or pressure in tank	Temperature and pressure relief valves are made to operate if the water temperature exceeds 210°F or water pressure exceeds the pressure rating of the safety relief valve. If trouble is excessive temperature, then thermostat is not shutting off at the right setting and thermostat must be replaced.

SECTION V - SERVICING & REPLACEMENT OF PARTS

WARNING / CAUTION

Before servicing or replacing any part make sure to turn the power supply switch to the OFF position.

SURFACE TEMPERATURE HIGH LIMIT CUT-OFF

1. Disconnect power from unit.
2. Remove access cover.
3. Disconnect the four (4) 14 gauge wires.

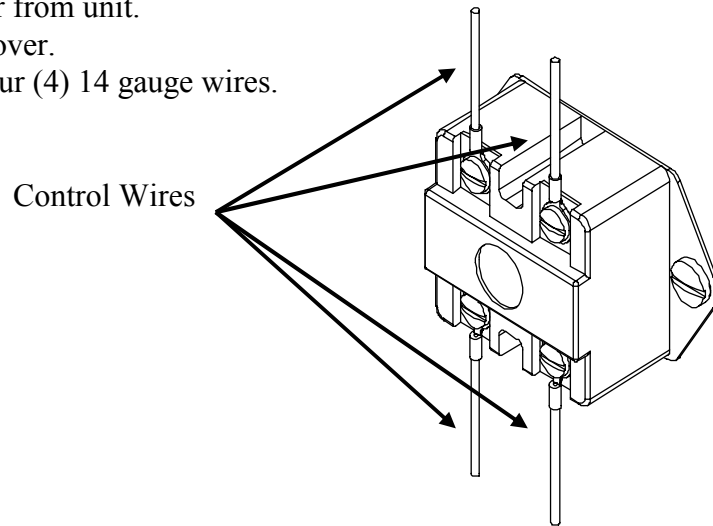

4. Remove the two (2) mounting screws.

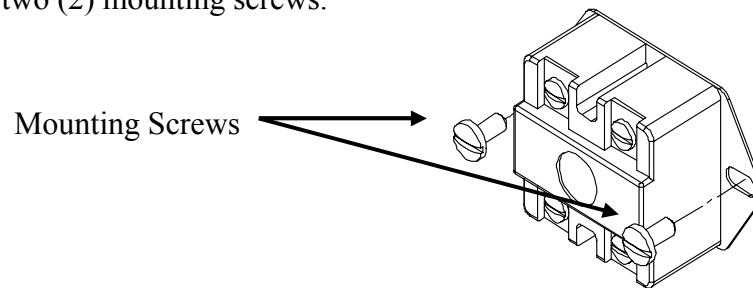

5. Replace control and install new high limit switch by performing above steps in reverse order. See wiring diagram included with drawing for assistance.

IMMERSION TEMPERATURE HIGH LIMIT CUT-OFF

1. Disconnect power from unit.
2. Remove access cover.
3. Remove high limit cover screw and cover.

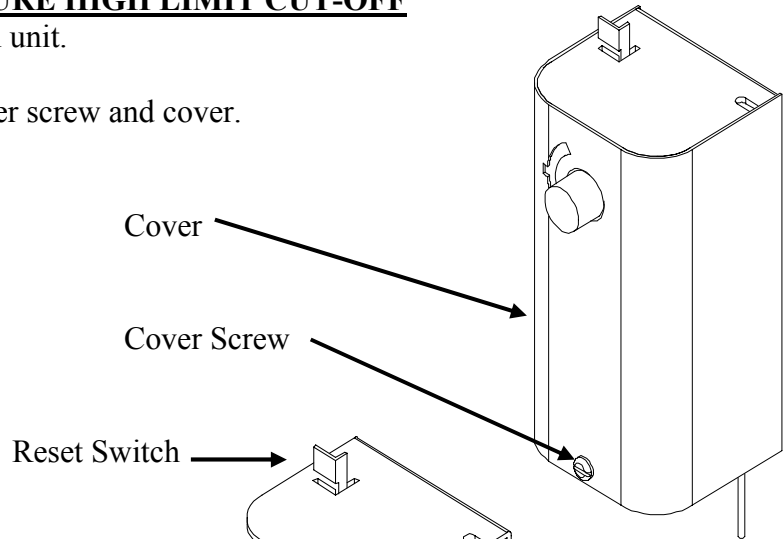

4. Disconnect the two (2) 14 gauge wires.

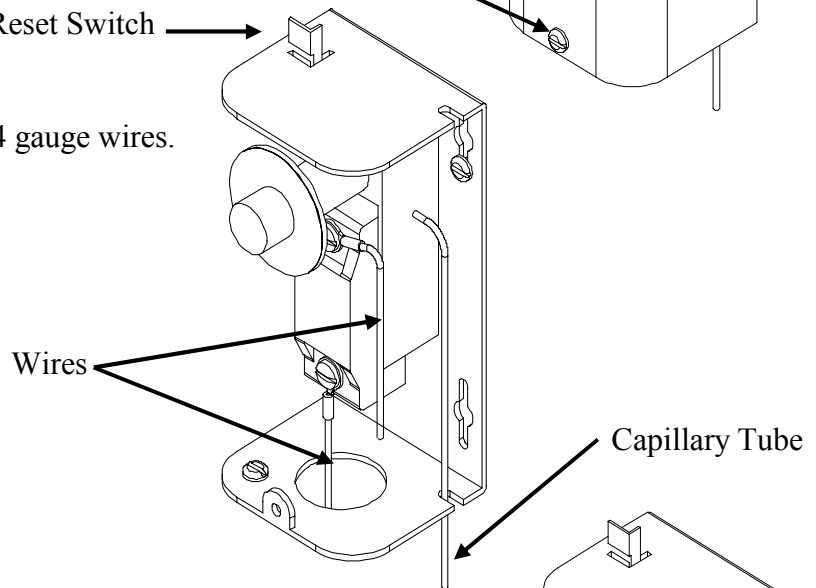

5. Remove capillary tube and bulb from thermowell
6. Remove two (2) mounting screws.

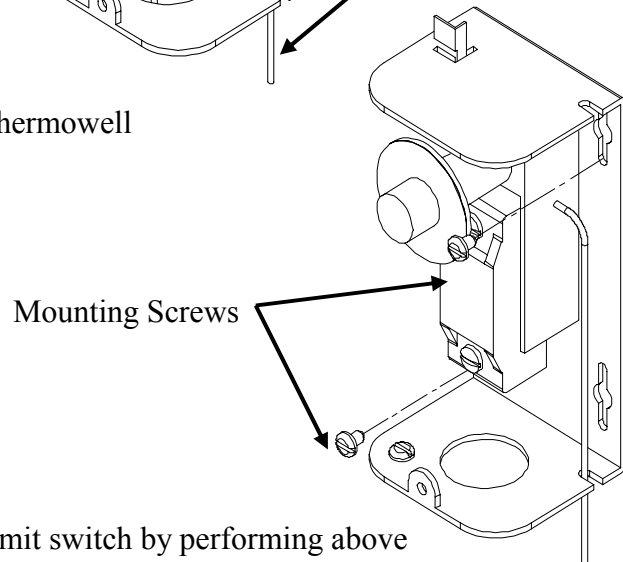

7. Remove control and install new high limit switch by performing above steps in reverse order. (Note: Be sure to place capillary tube into slot in base prior to installing cover.)

HEATING ELEMENT

1. Disconnect power from unit.
2. Shut off incoming water supply.
3. Attach hose to drain connection.
4. Lift manual release lever on relief valve to let air into system or break union on outgoing water line.
5. Drain water from tank.
6. Disconnect the wires from the heating element terminals.
7. Remove the 3/8-16 nuts.

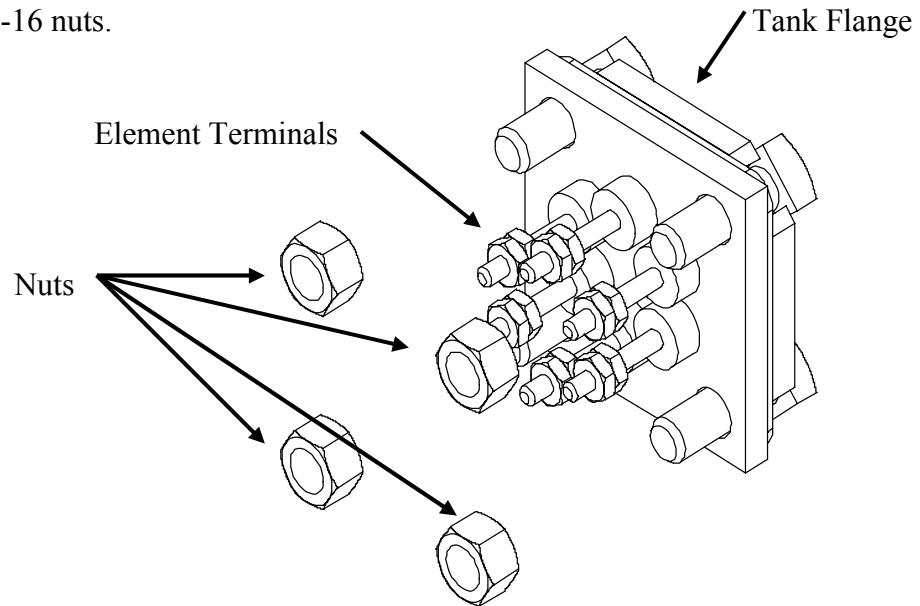

8. Withdraw element assembly and remove gasket.

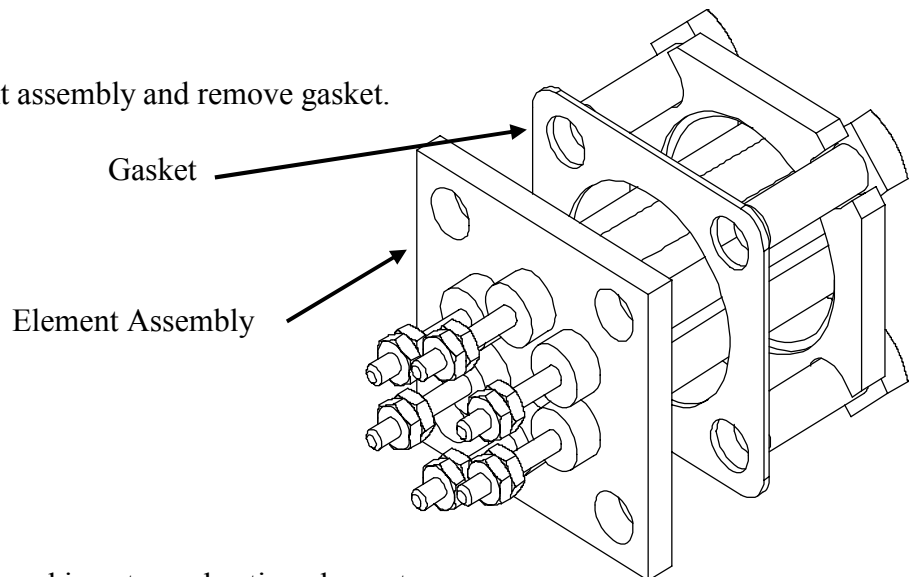

9. Install new gasket and insert new heating element.
10. Rewire element according to the voltage and phase rating of the unit as shown below.
11. Fill tank and check around gasket for any leaks.

JUMPER CONFIGURATION

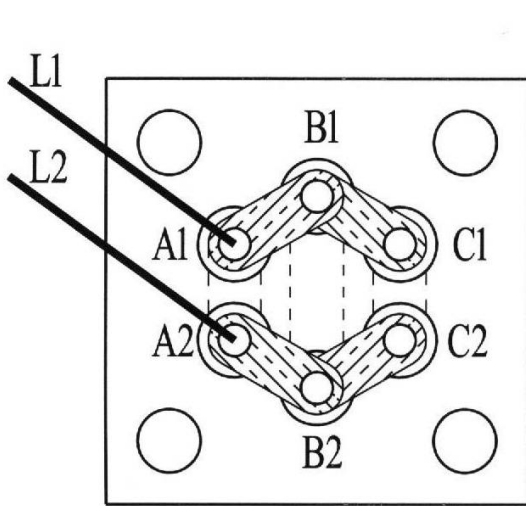

1 PHASE
208 OR 240 VOLT

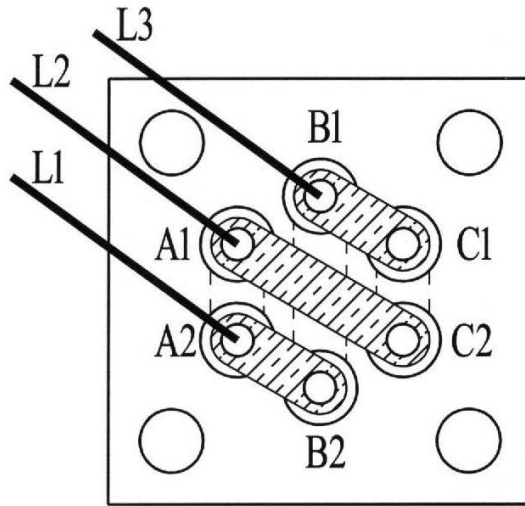

3 PHASE DELTA
208 OR 240 VOLT

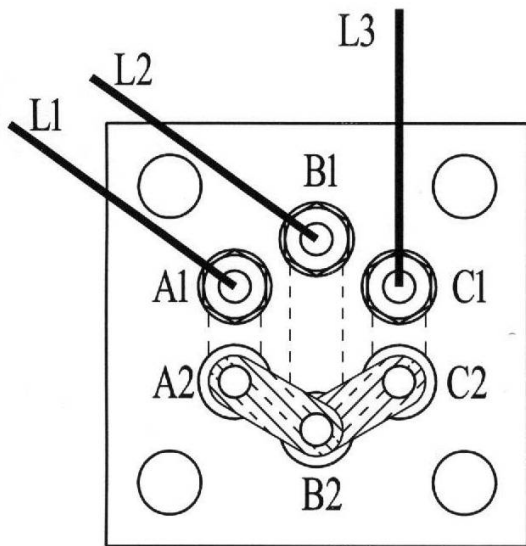

3 PHASE WYE
380 TO 575 VOLT

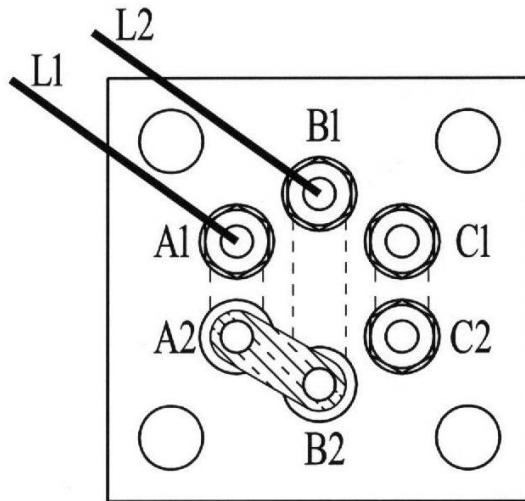

1 PHASE
480 VOLT

SURFACE MOUNTED THERMOSTAT

1. Disconnect power from unit.
2. Remove access cover and locate thermostat.
3. Disconnect the two (2) 14 gauge wires.

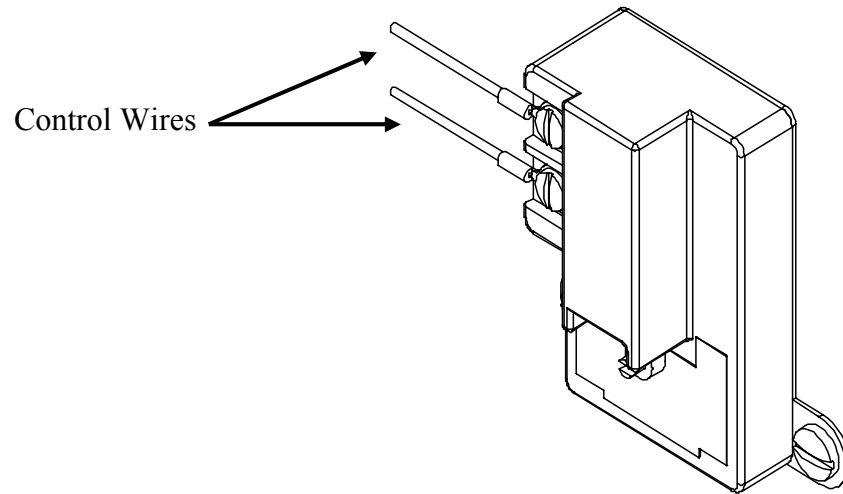

4. Remove two (2) mounting screws.

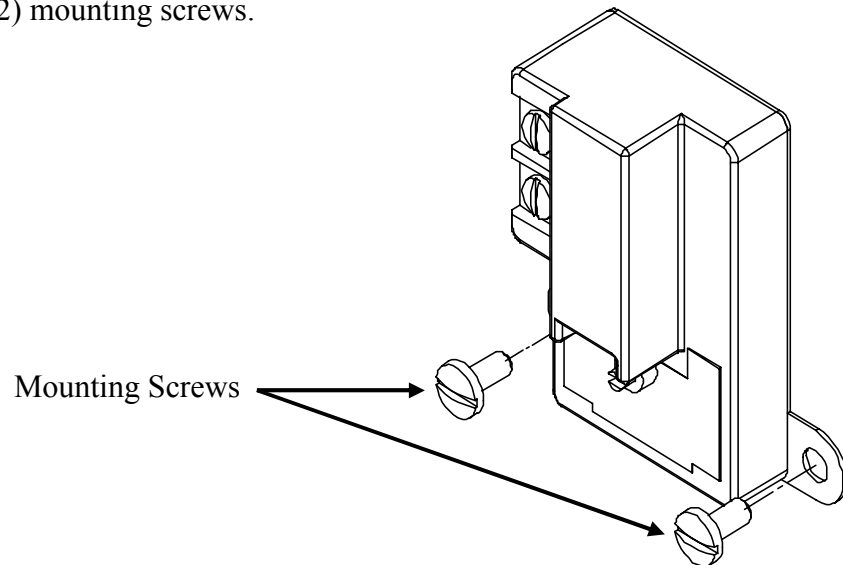

5. Replace thermostat using the reverse procedure.

IMMERSION THERMOSTAT

1. Disconnect power from unit.
2. Remove access cover and locate thermostat.
3. Remove high limit cover screw and cover.

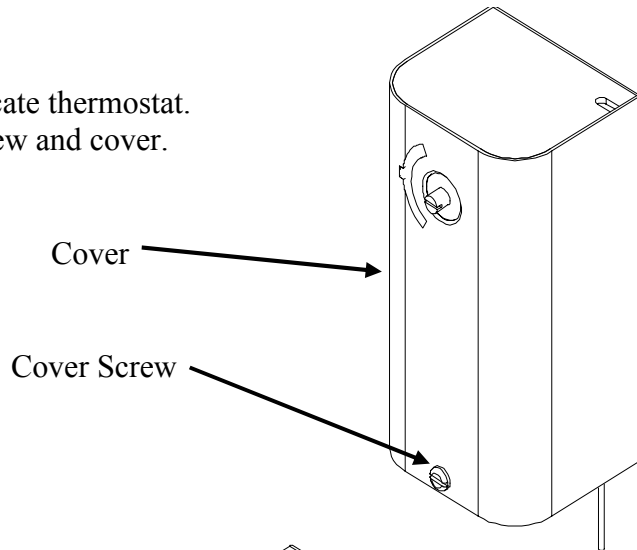

4. Disconnect the two (2) 14 gauge wires.

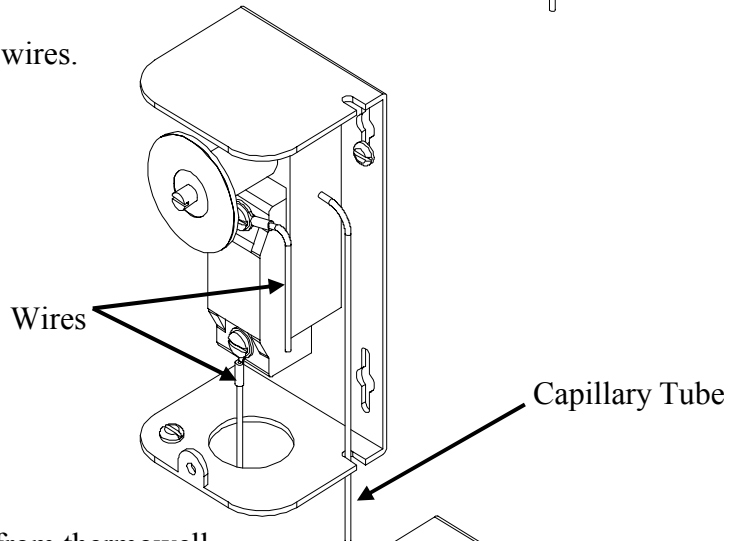

5. Remove capillary tube and bulb from thermowell.
6. Remove two (2) mounting screws.

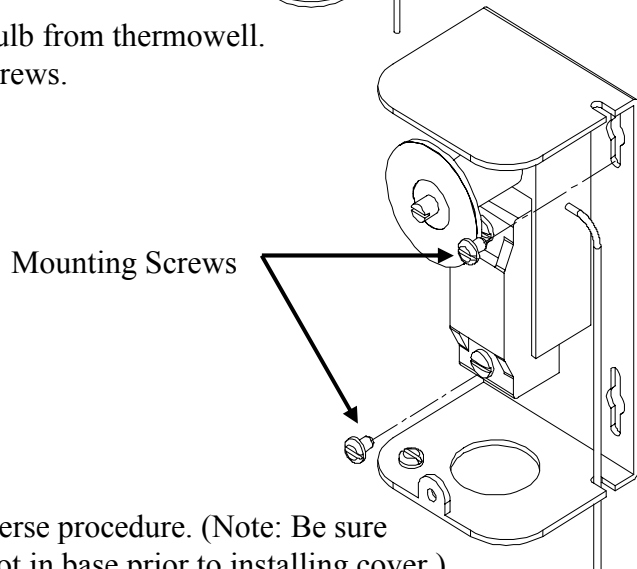

7. Replace thermostat using reverse procedure. (Note: Be sure to place capillary tube into slot in base prior to installing cover.)

MAGNETIC CONTACTOR

1. Disconnect power from unit.
2. Disconnect line and load wires to contactor.
3. Disconnect two (2) 14 gauge control circuit wires.

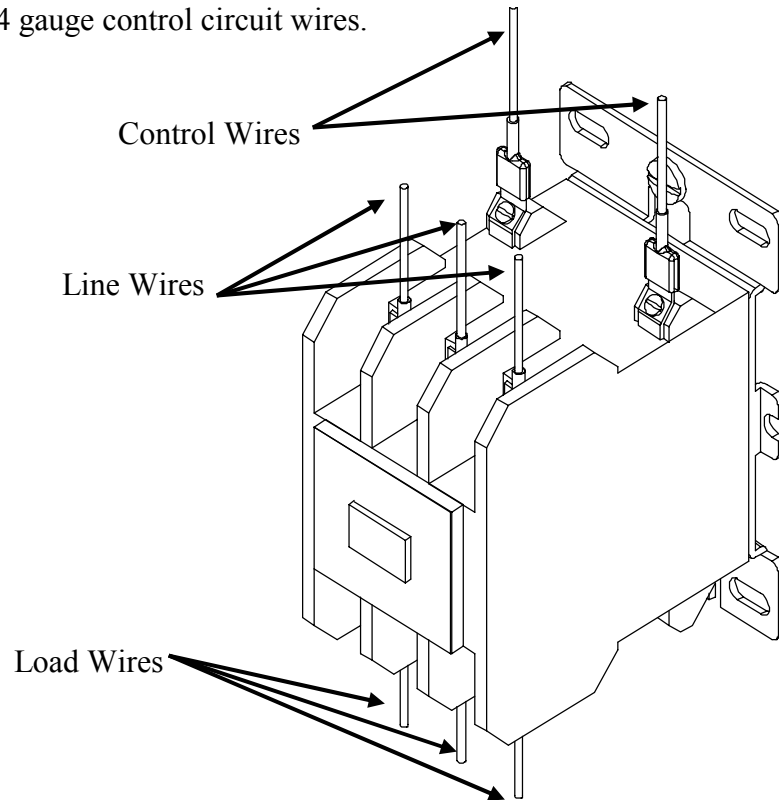

4. Loosen two (2) holding screws and remove contactor.

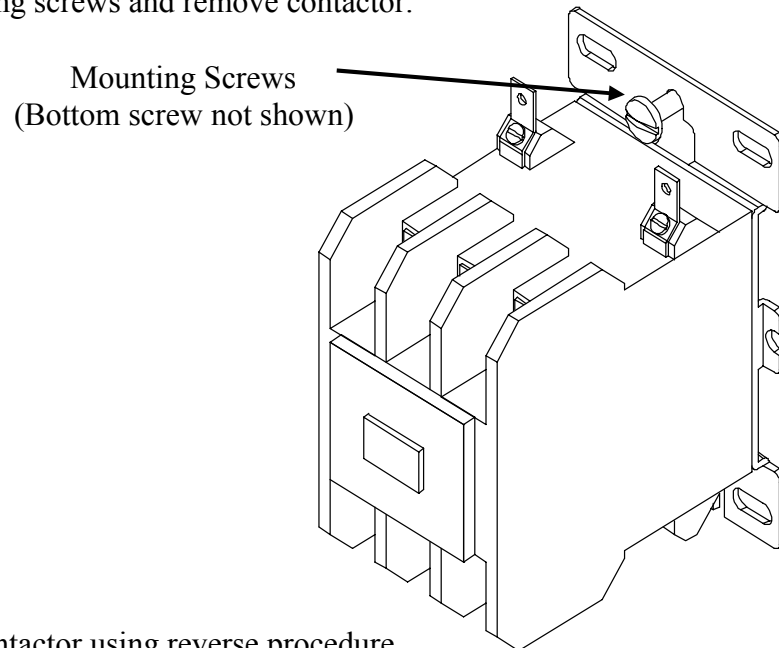

5. Replace with new contactor using reverse procedure.

RELIEF VALVE

1. Disconnect power from unit.
2. Shut off incoming water supply.
3. Lift test lever on relief valve to relieve pressure in tank.
4. Disconnect overflow piping.
5. Unscrew relief valve, remove assembly and replace with new one.
6. Connect overflow piping.
7. Turn on incoming water supply and check for leaks.
8. Turn safety switch to ON position.

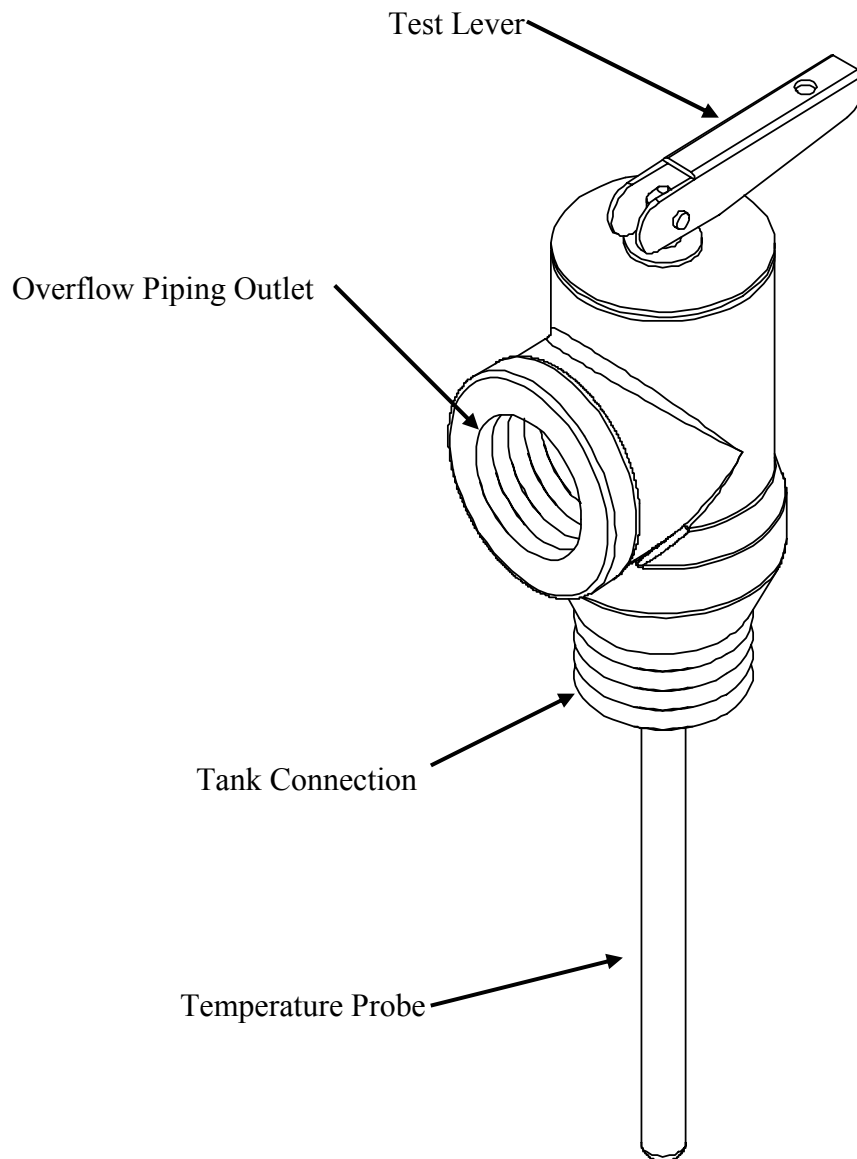

SECTION VI – MISCELLANEOUS CHARTS AND FORMULAS

ELEMENT CHART

Element Part #	Immersion Length	Resistance (Ohms)			
		Hairpin	1 Φ	3 Φ DELTA	3 Φ WYE
2-38683N	13"	57.6	19.2	57.6	38.6
3-38683N	13"	43.2	14.4	43.2	28.9
4-38683N	13"	34.4	11.5	34.4	23.0
5-38683N	13"	27.9	9.3	27.9	18.7
6-38683N	13"	21.6	7.2	21.6	14.5
7-38683N	13"	17.1	5.7	17.1	11.5
8-38683N	13"	14.4	4.8	14.4	9.6
9-38683N	15"	12.1	4.0	12.1	8.1
10-38683N	15"	9.1	3.0	9.1	6.1
11-38683N	15"	7.5	2.5	7.5	5.0

FORMULAS

RECOVERY

$$\text{GPH} \times \text{_____} \text{ } ^\circ\text{F } \Delta\text{T} \times 0.00244 = \text{KW}$$

$$\text{KW} \times 410 \div \text{GPH} = \text{_____} \text{ } ^\circ\text{F } \Delta\text{T}$$

$$\text{KW} \times 410 \div \text{_____} \text{ } ^\circ\text{F } \Delta\text{T} = \text{GPH}$$

Note: 1 KW will heat 4.1 GPH at a 100^oF Δ T

ELECTRICAL

$$\frac{\text{KW} \times 1000}{\text{Volts}} \div 1.73 = \text{Amps } 3 \Phi$$

$$\frac{\text{KW} \times 1000}{\text{Volts}} = \text{Amps } 1 \Phi$$

METRIC CONVERSION

$$\text{Liters} \times 0.2641 = \text{Gallons}$$

$$\text{Gallons} \times 3.79 = \text{Liters}$$

$$\text{Gallons} \times 0.003785 = \text{m}^3$$

$$\text{m}^3 \times 264.2 = \text{Gallons}$$

$$1^\circ\text{C } \Delta\text{T} = 1.8^\circ\text{F } \Delta\text{T}$$

$$^\circ\text{F} = (^\circ\text{C} \times 1.8) + 32$$

$$^\circ\text{C} = (^\circ\text{F} - 32) \times 0.556$$

$$\text{psi} \times 0.06896 = \text{Bar}$$

$$\text{Bar} \times 14.5 = \text{psi}$$

$$\text{psi} \times 6.86 = \text{kPa}$$

$$\text{kPa} \times 0.1456 = \text{psi}$$

$$\text{Lbs} \times 0.4536 = \text{Kg}$$

$$\text{Kg} \times 2.2 = \text{Lbs}$$

$$\text{Watts/Sq.Cm.} \times 6.4 = \text{Watts/Sq.In.}$$

$$\text{Watts/Sq.In.} \times 0.155 = \text{Watts/Sq.Cm.}$$

TORQUE VALUES

BOLT SIZE	18-8 S/S IN.-LBS.	BRASS IN.-LBS.	SILICON BRONZE IN.-LBS.	ALUMINUM 2024-T4 IN.-LBS.	316 S/S IN.-LBS.	MONEL IN.-LBS.
4-40	5.2	4.3	4.8	2.9	5.5	5.3
4-48	6.6	5.4	6.1	3.6	6.9	6.7
5-40	7.7	6.3	7.1	4.2	8.1	7.8
5-44	9.4	7.7	8.7	5.1	9.8	9.6
6-32	9.6	7.9	8.9	5.3	10.1	9.8
6-40	12.1	9.9	11.2	6.6	12.7	12.3
8-32	19.8	16.2	18.4	10.8	20.7	20.2
8-36	22.0	18.0	20.4	12.0	23.0	22.4
10-24	22.8	18.6	21.2	13.8	23.8	25.9
10-32	31.7	25.9	29.3	19.2	33.1	34.9
1/4-20	75.2	61.5	68.8	45.6	78.8	85.3
1/4-28	94.0	77.0	87.0	57.0	99.0	106.0
5/16-18	132	107	123	80	138	149
5/16-24	142	116	131	86	147	160
3/8-16	236	192	219	143	247	266
3/8-24	259	212	240	157	271	294
7/16-14	376	317	349	228	393	427
7/16-20	400	327	371	242	418	451
1/2-13	517	422	480	313	542	584
1/2-20	541	443	502	328	565	613
9/16-12	682	558	632	413	713	774
9/16-18	752	615	697	456	787	855
5/8-11	1110	907	1030	715	1160	1330
5/8-18	1244	1016	1154	798	1301	1482
3/4-10	1530	1249	1416	980	1582	1832
3/4-16	1490	1220	1382	958	1558	1790
7/8-9	2328	1905	2140	1495	2430	2775
7/8-14	2318	1895	2130	1490	2420	2755
1-8	3440	2815	3185	2205	3595	4130
1-14	3110	2545	2885	1995	3250	3730

SECTION VII – ABS TYPE APPROVAL PROGRAM





CERTIFICATE NUMBER NY507619
 PLANT LOCATION STRATFORD, CT
 ABS OFFICE NEW YORK, NEW JERSEY

CERTIFICATE OF Manufacturing Assessment

This is to Certify that a representative of this Bureau did, at the request of
 Hubbell The Electric Heater Company

Attend their facilities at the location noted above, in order to carry out an audit of their facilities and associated quality assurance and quality control procedures. The facility is considered capable of consistently manufacturing;

PACKAGED ELECTRIC STORAGE TYPE WATER HEATERS

in compliance with their ABS Product Design Assessment Certificates and the designated standards defined therein. The product listed on their current Product Design Assessment Certificates are eligible to be placed on this Bureau's *List of Type Approved Products*, subject to annual facility audits by a representative of this Bureau, and renewal of this Certificate after five (5) years.

ISSUE DATE 24 MARCH 2004 EXPIRATION DATE 23 MARCH 2009

SURVEYOR'S SIGNATURE *[Signature]*

FIRST ANNUAL ENDORSEMENT 31 MARCH 2005 *[Signature]*

SECOND ANNUAL ENDORSEMENT 27 APRIL, 2006 *[Signature]*

THIRD ANNUAL ENDORSEMENT 10 MAY, 2007 *[Signature]*
 NY 850630

FOURTH ANNUAL ENDORSEMENT

AB257 (09-03)

Note: This certificate evidences compliance with one or more of the Rules, Guides, standards, or other criteria of American Bureau of Shipping, or a statutory, industrial, or manufacturer's standard, and is issued solely for the use of the Bureau, its committees, its clients, or other authorized entities. This certificate is governed by the terms and conditions on the reverse side hereof.

ABS Type Approval, Manufacturing Assessment
 AQS and RQS, TWZ-017-03-P01-W003

Attachment B - Revision 1

Page 1 of 2



Certificate of Type Approval

This is to certify that Hubbell-The Electric Heater Company
has met the requirements of ABS Product Type Approval for
Packaged Electric Storage Type Water Heaters
Model Name(s): (M) SE Series

Presented to:

Hubbell-The Electric Heater Company
45 Seymour Street
P.O. Box 288
Stratford
Connecticut
06497-0288

Intended Service:

Designed to provide potable hot water for Onboard Commerical Marine reequirements (Non-Pleasure Craft).
Units are designed for Non-Weather deck locations.

Description:

Commercial Electric Type Water Heaters. Vertical or Horizontal, Jacketed, Insulated including all necessary and
required operating controls.

Ratings:

Maximum Working Pressure: 100 psig, Maximum Design Temperature: 98.9 degrees C (210 degrees F),
Capacity: up to 120 Gallons (U.S.)

Service Restrictions:

Not Applicable

Comments:

(a). Welding is to be performed in accordance with approved procedures. Procedure qualification records,
welder qualifications and production welds are to be maintained for records. (b). Hydrostatic testing is to be
performed at the plant of manufacturer for each unit and certified test reports are to be maintained for records.

(c). Relief valve settings are to be in accordance with 4/2.23.3 of the Rules. (d). Overcurrent protection shall be supplied by the end user at the time of final installation.

ABS Rules:

Applicable portion of the 1998 ABS Rules for Building and Classing Steel Vessels.

National Standards:

UL STD 1453; USCG # 46 CFR Part 53.01

International Standards:

Government Authority:

Others:

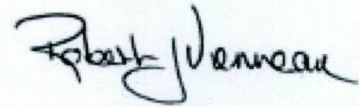

Manager, ABS Programs

ABS has used due diligence in the preparation of this certificate and it represents the information on the product in the ABS Records as of the date and time the certificate was printed. Type Approval requires Drawing Assessment, Prototype Testing and assessment of the manufacturer's quality assurance and quality control arrangements. Limited circumstances may allow only Prototype Testing to satisfy Type Approval. The approvals of Drawings and Products remain valid as long as the ABS Rule, to which they were assessed, remains valid. ABS cautions manufacturers to review and maintain compliance with all other specifications to which the product may have been assessed. Further, unless it is specifically indicated in the description of the product; Type Approval does not necessarily waive witnessed inspection or survey procedures (where otherwise required) for products to be used in a vessel, MODU or facility intended to be ABS classed or that is presently in class with ABS. Questions regarding the validity of ABS Rules or the need for supplemental testing or inspection of such products should, in all cases, be addressed to ABS.

Printed on : 2002-08-16 09:10:26.73